

**PSCE 315C B**  
**PSCE 310C B**



3600



3200



**C-LINE**

*Lifting equipment*

**EN** → Reversible low-profile electrohydraulic scissors lift for cars, SUVs and vans



**Reversible low-profile electrohydraulic scissors lift for cars, SUVs and vans;** ideal for tyre specialists, car workshops, and body repairers.  
**Runway levelling guaranteed** by 2 sturdy anti-torsion connection bars.

- 1 Low voltage control unit with "dead-man" control system.
- 2 Runways with suspended flaps which also act as vehicle access ramps.



Available in on-floor and pit installation versions.

### EN → Supplied accessories

All models complete with:

- ✓ Automatic engagement of mechanical safety locks with pneumatic release system
- ✓ Anti-crushing foot guard.
- ✓ Set of 4 rubber pads

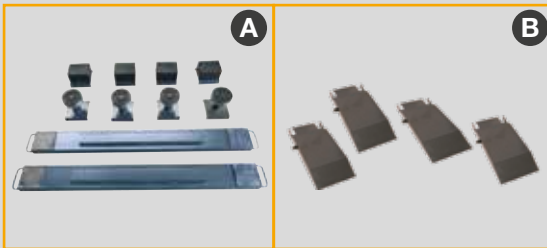

### EN → Optional accessories

- A Pair of cross pieces and pads for off-road vehicles
- B Extension ramps set (4 pcs)

### EN → Technical Data

Model	PSCE 315C B	PSCE 310C B
Lift capacity	3600 kg	3200 kg
Lifting time	25 s	
Three phase motor	400/230V - 3kW - 3Ph - 50/60Hz	
Single phase motor	230V - 3kW - 1Ph - 50/60Hz	
Max. lifting height	1000 mm	
Lift min. height	120 mm	

### EN → Overall Dimensions

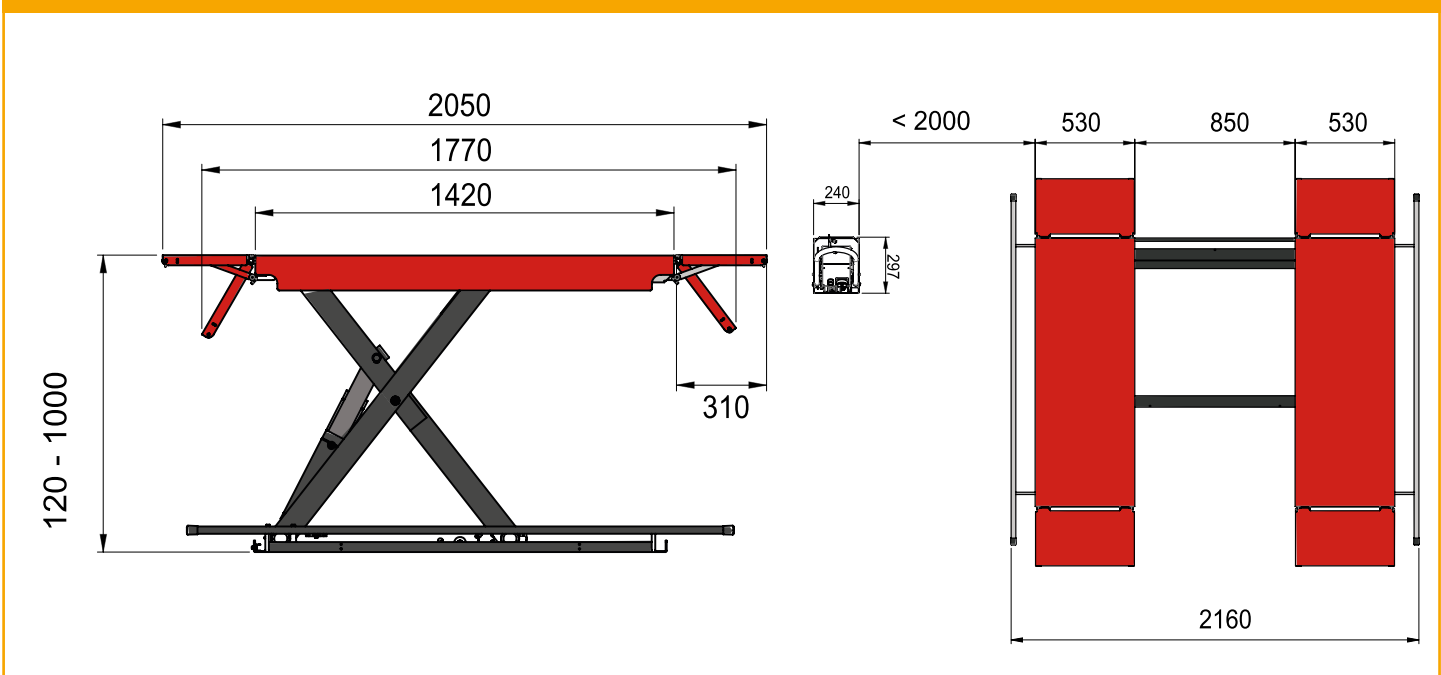

The manufacturer reserves the right to modify the features of its products at any time.

Cod. DPSC000461A - 01/2023